

October 15, 1975

REVISION 2
KWM-2 SERVICE BULLETIN NO 9

Attached is a revised version of KWM-2 Transceiver Service Bulletin No 9, titled "Convert KWM-2 to KWM-2A" originally dated 15 June 1972.

The reason for this revision is to correct erroneous Collins part numbers of items appearing in the modification kit parts list and in figure 1, sheet 2.

Black bars in the margin show where the changes are made. This revised issue entirely replaces the original.

KWM-2 TRANSCEIVER (522-1611-000)
FREQUENCY SELECTING SECTION

SERVICE BULLETIN NO 9

CONVERT KWM-2 TO KWM-2A

Modification kit, Collins part number 622-0803-001, when installed converts the KWM-2 amateur band transceiver to a general coverage transceiver KWM-2A by providing crystal positions for 14 additional 200-kHz frequency bands.

Approximately 12 hours are required to install this modification.

NOTE: Persons unfamiliar with electronic circuits or who lack circuit wiring experience should not attempt this modification.

Modification kit number 622-0803-001 may be ordered from any Collins equipment dealer or authorized service agency. If preferred, the transceiver may be shipped to a service agency where the modification will be made; consult the agency for cost and instructions before shipping. Refer to this KWM-2 Service Bulletin No 9 when consulting a Collins dealer or agency concerning the modification.

INSTALLATION PROCEDURES

Before starting the installation, carefully check all parts against the list in the table. Refer the description and part number of any irregularities to the dealer or agency who supplied the kit.

NOTE: General coverage crystals are not furnished.

- a. Remove four rubber feet and the holding screws from the bottom of the transceiver. Remove two unpainted screws under the front edge of the lid, then slide the transceiver out of the cabinet.
- b. Remove and discard the coaxial cable that connects XV13A-2 to the crystal switch. Refer to the wiring drawing in figure 1.
- c. Remove and discard capacitor C266 from XV13A-2.
- d. Remove the pointer knob from the frequency band switch.
- e. Viewing the front of the panel, measure approximately 4.062 (4-1/16) inches in from the left edge and 2.593 (2-19/32) inches up from the bottom edge. At this intersection, locate the existing 3/8-inch hole at the reverse side of the front panel. Use a 1/4-inch drill bit and bore a pilot hole through the panel overlay coincident with the rear hole.

CAUTION: DO NOT MAR THE PANEL OVERLAY SURROUNDING THE HOLE.

- . Using a 0.687 (11/16) to 0.718 (23/32) inch spot face drill or counterbore, carefully bore through the 0.032-inch panel overlay.
- g. Loosen two setscrews and pull shaft to first shielded can. Carefully disassemble crystal switch section S2. From the kit install switch section S14 and reinstall S2 using new hardware specified in figure 1, bottom view. S14 is identical to S2 and should be oriented the same way as S2 (S2 mounting bracket may be removed from chassis to aid in S14 installation).
- h. Observe detail A-A in figure 1. Note the parts that make up the assembly and their relative positions, then install switch S15 and all other parts.
- i. Refer to the wiring diagram of figure 1. Install wires from S15 to S2 and S14. Then install coax from S15 to XV13. Wire socket XY3 and switch S14.
- j. Observe detail B-B in figure 1. Mount crystal socket XY3 using kit hardware specified in the drawing.
- k. Transfer the amateur band crystals from XY1 to their respective positions in XY3 (under the chassis).
- l. Plug the desired general coverage crystals into the top chassis socket XY1. Consult the KWM-2 or KWM-2A instruction book section OPERATION OUTSIDE THE AMATEUR BANDS.
- m. Place the new bar knob on switch S15 shaft (refer to detail assembly A-A).
- n. Discard the old band-switch knob and replace with new knob from the kit. Orient rotating tab of S14 with rotating tab of S2. Reinsert shaft and tighten setscrews. Rotate band-switch knob and note that the tabs of S2 and S14 make proper contact at each detent position.
- o. Clean the KWM-2 frequency escutcheon with alcohol. Remove tape from back of the KWM-2A overlay plate and position the plate on the escutcheon (over the KWM-2). Align the edges and press tight with finger pressure.
- p. Check all wiring and solder connections carefully.
- q. Turn the transceiver on, connect an antenna, and after warmup, check the receiver on each frequency band (use a signal generator to check inactive bands). If the reception is degraded on any band, recheck the procedure steps (particularly step k).
- r. Slide transceiver into a cabinet and replace feet and screws removed in procedure a.

OPERATION

The bar knob on the top of the new band switch frame operates switch S15 and transfers the oscillator grid from the amateur crystals switch S14 to the general coverage crystals switch S2. The bar knob moves the frequency select card which identifies the new set of band frequencies. To identify new bands, hand letter the frequency of the low end of the band on the window card. Refer to the KWM-2/2A instruction book.

PARTS TABLE

Descriptions of parts furnished with modification kit (622-0803-001) are listed with Collins part numbers.

SERVICE BULLETIN

PARTS LIST FOR MODIFICATION KIT 622-0803-001

STEM NUMBER	QUANTITY FURNISHED	COLLINS PART NUMBER	DESCRIPTION
1	1	259-0980-000	Rotary switch section S15
2	2	269-2401-000	Tubular spacer (1/8 in)
3	2	269-1403-000	Tubular spacer (1/4 in)
4	1	269-2023-000	Switch section S14
5	1	328-0473-000	Setscrew (8-32 x 3/16)
6	2	328-0512-010	Setscrew (6-40 x 1/8)
7	1	328-0506-020	Setscrew (6-40 x 3/16)
8	5	342-0048-000	Machine screw (4-40 x 1/2)
9	1	343-0289-000	Machine screw (4-40 x 1/2)
10	2	343-0291-000	Machine screw (4-40 x 3/4)
11	1	373-0083-000	Shakeproof washer (15/32)
12	1	334-4030-000	Hexnut (15/32 - 32)
13	1	334-4060-000	Hexnut (3/8 - 32)
14	.2 ft	152-1375-000	Sleeve insulation
15	2	421-2220-000	Electrical wire
16	15	428-4824-000	Hookup wire
17	3	540-9049-003	Mtg post
18	1	544-2825-002	Crystal socket XY3
19	1	544-7261-000	Crystal cover assy
20	1	544-7263-000	Frequency selector card
21	1	544-7266-000	Special nut
22	1	544-0779-004	Pointer knob
23	1	544-7268-002	Bar knob
24	1	544-7277-004	Frequency selector frame
25	1	609-1476-001	RF cable
26	1	609-1583-001	KWM-2A overlay plate
27	1	790-0408-001	Crankbell
28	1	024-0167-000	Wrench sch screw no 6

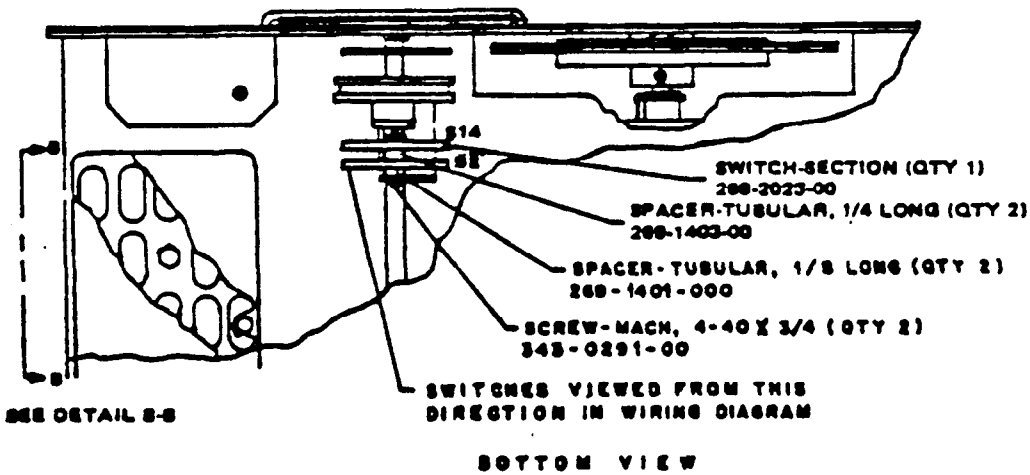
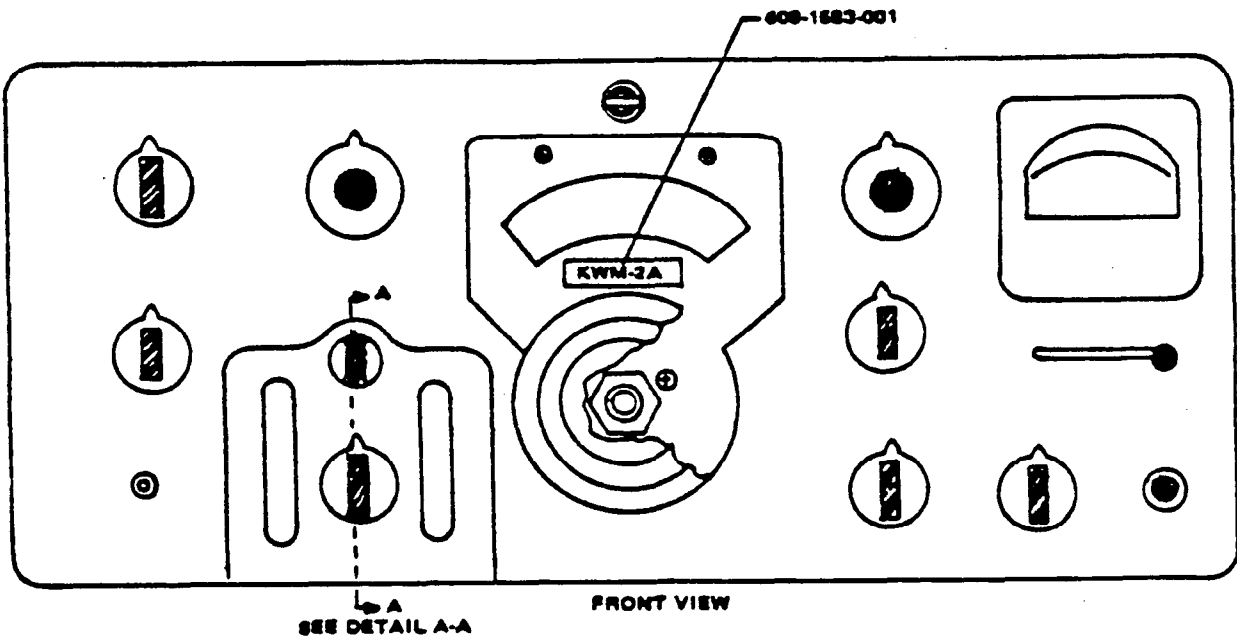
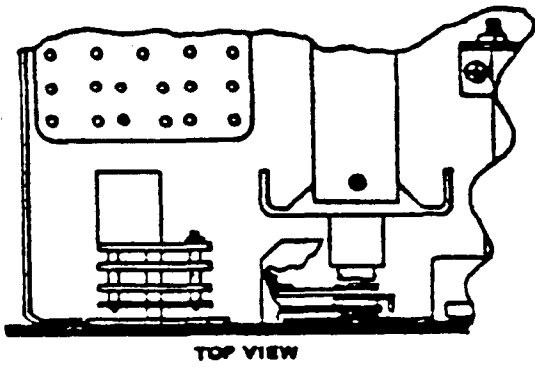

KWM-2 Amateur Transceiver, Additional
Crystal Board, Installation Drawing
Figure 1 (Sheet 1 of 3)

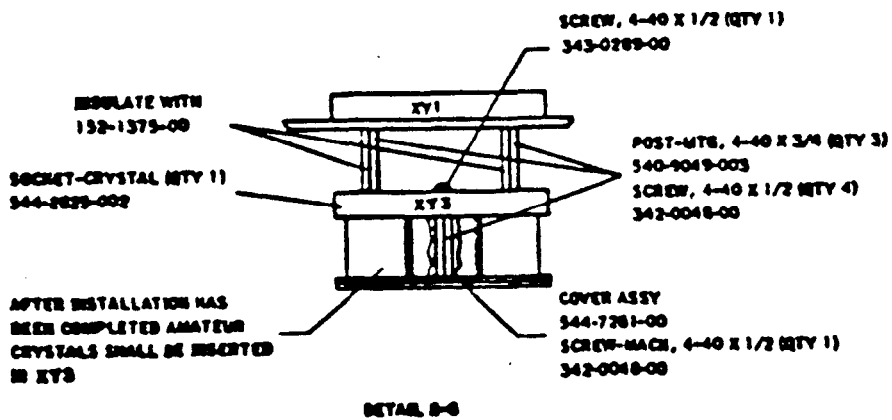
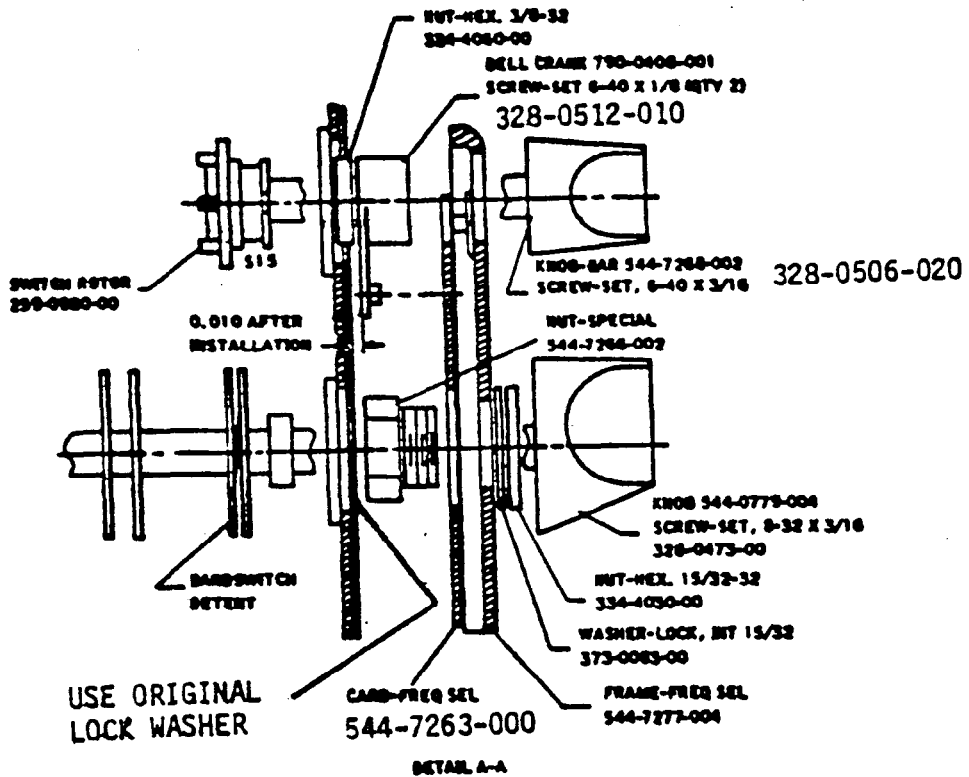

KWM-2 Amateur Transceiver, Additional
Crystal Board, Installation Drawing
Figure 1 (Sheet 2)

Apr 15/73
2 - Oct 15/75

THIS LINE WHERE CHASSIS
HITS FRONT PANEL IS
REPRESENTED DOTTED ON
WIRING DIAGRAM. IT SHOWS
WAFERS ON ONE SIDE AND
SWITCH ON OTHER

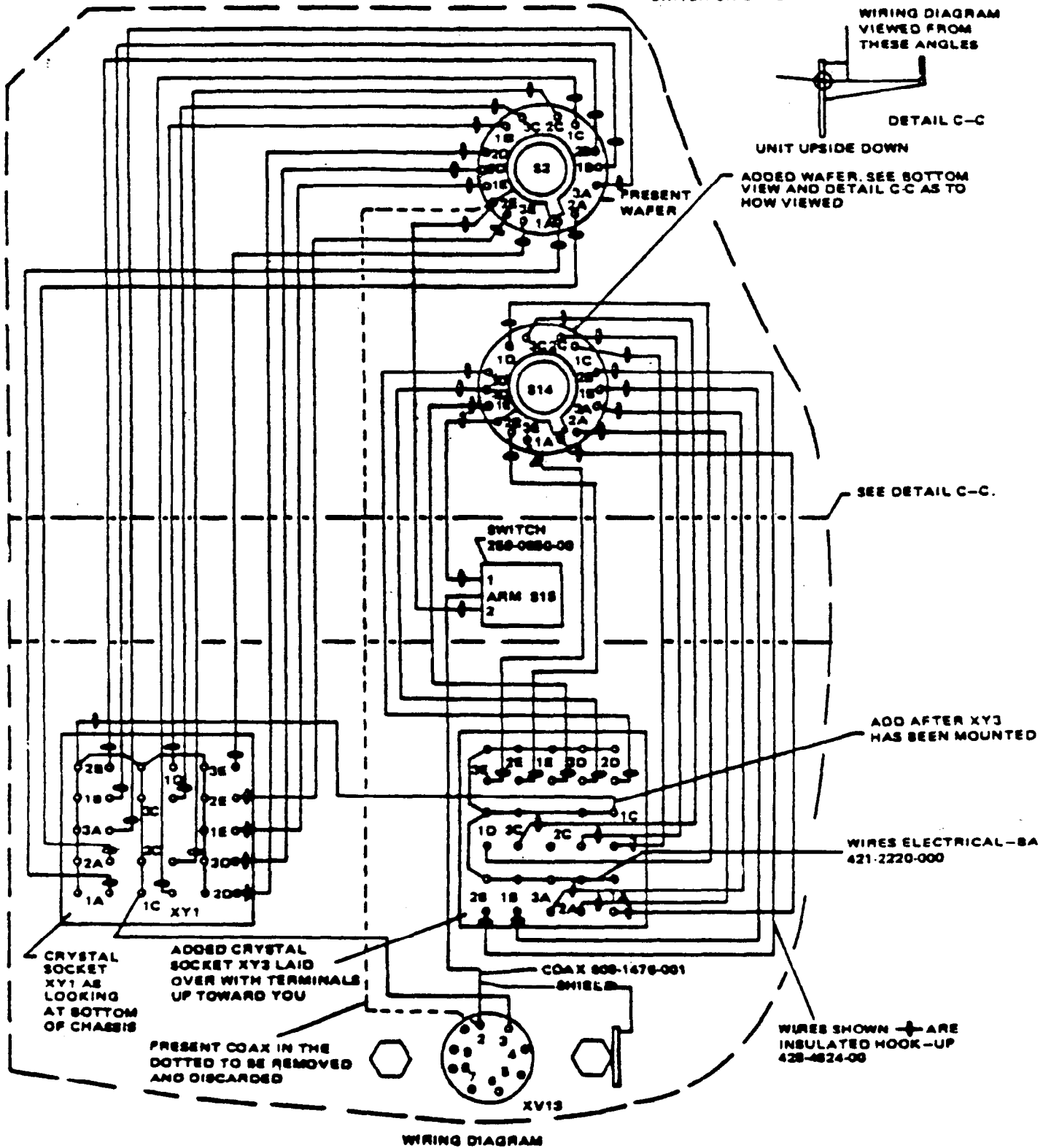

KWM-2 Amateur Transceiver, Additional
Crystal Board, Installation Drawing
Figure 1 (Sheet 3)

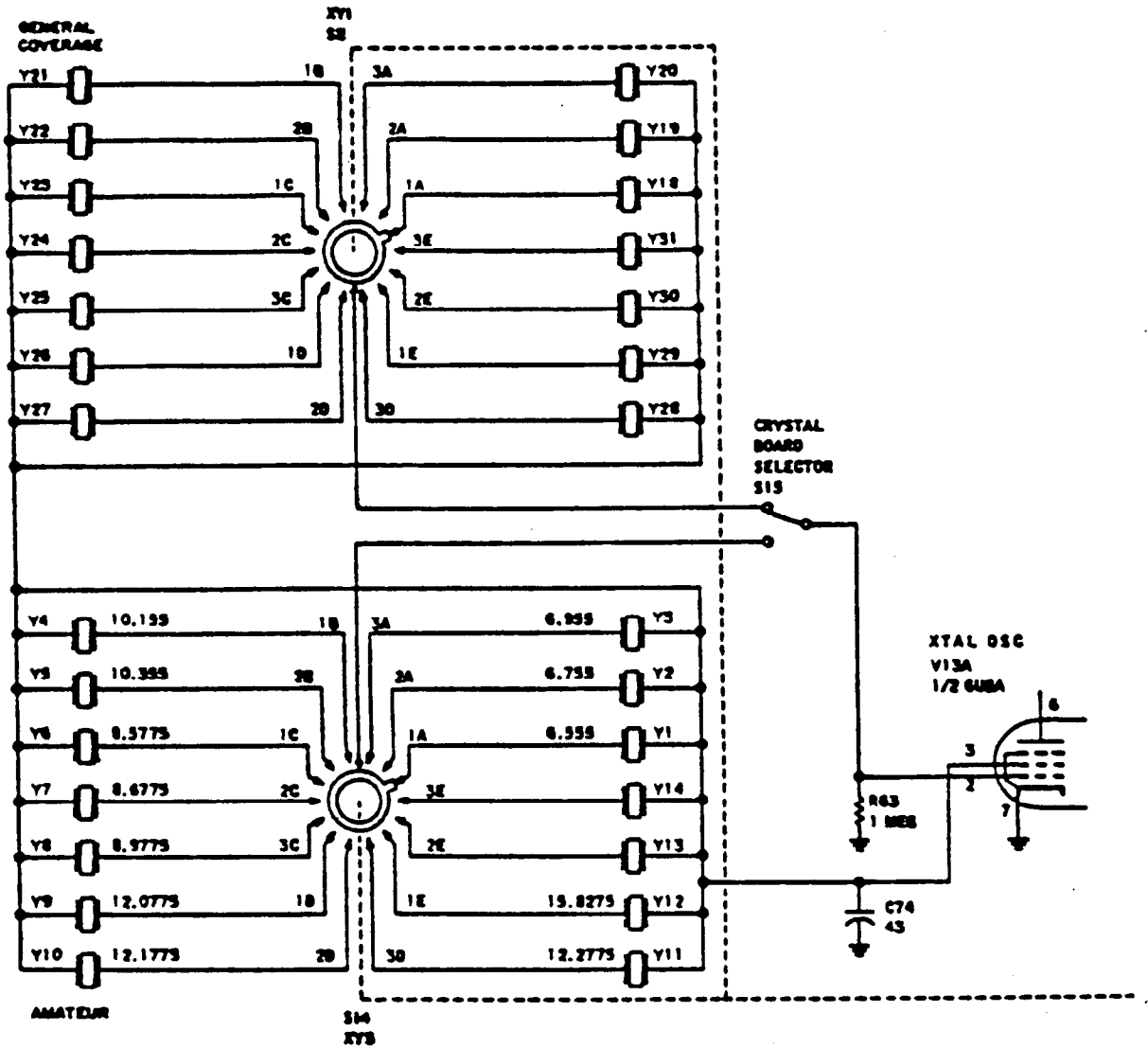

KWM-2 Amateur Transceiver Additional Crystal Board,
Schematic Diagram
Figure 2